

For Low Pressure

# Mini Cupla

Standard type for use on equipment for welding and gas cutting, etc.

<b>Working pressure</b> 0.7 0.7 MPa (7 kgf/cm <sup>2</sup> )	<b>Valve structure</b> One-way shut-off	<b>Applicable fluids</b> Oxygen, Fuel Gas
---	--	--

## Exclusively for oxyacetylene equipment. Many variations with higher flow rates!

- From cylinders to torches, all piping connections associated with welding and cutting equipment are push-to-connect operations.
- Double-lip seal prevents minor leak during connection. Oxygen and fuel gas Cuplas have different sizes to prevent accidental interconnection.
- Pressure loss is minimized to achieve higher flow rate.
- Various types of end configurations have been standardized to comply with a wide range of welding and cutting equipment applications. Sockets themselves or plugs themselves are interchangeable with Mini Cupla Super's counterparts.
- Line Cupla Mini is also available for multiple piping.

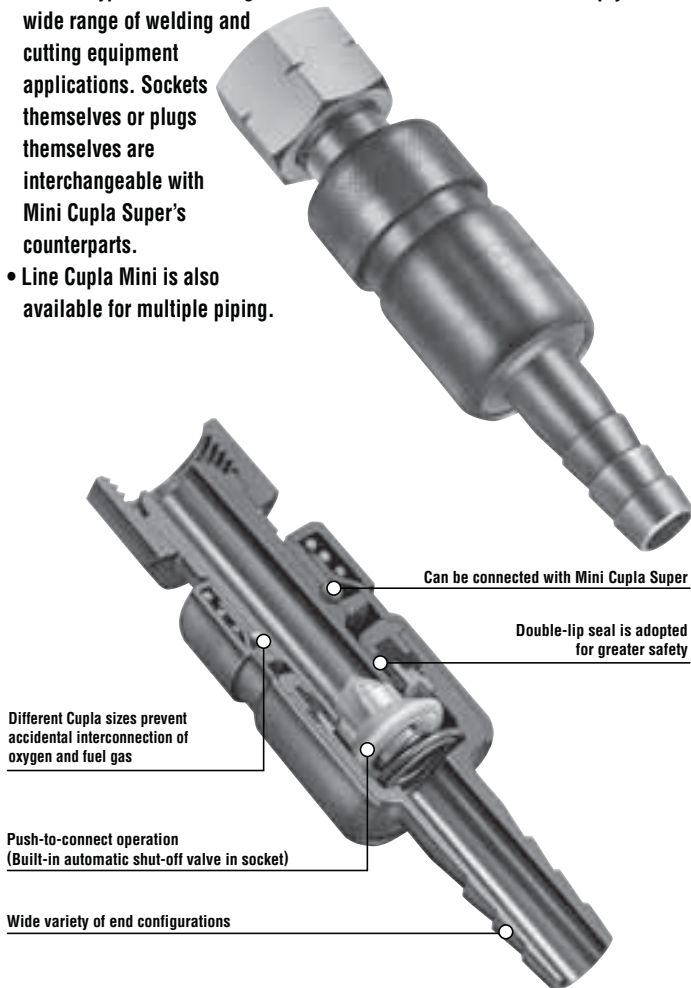

### Structure and Principle of Backflow Prevention

#### Plug with backflow stop valve

Plugs with backflow stop valve in Mini Cupla are designed exclusively for gas welding/cutting to prevent occurrence of gas mixing. Possible backflow of gas during operation can be stopped by cutting the back flow into the cylinder or line. Such valve is adopted in both fuel gas and oxygen plug.

Cross-section sketch showing the structure

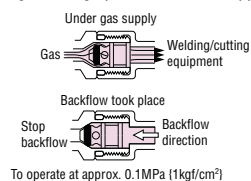
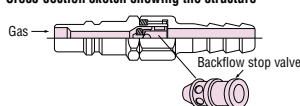

### Specifications

Body material	Brass			
Size	1/4" • 5/16" • 3/8"			
Working pressure MPa (kgf/cm <sup>2</sup> )	0.7 {7}			
Pressure resistance MPa (kgf/cm <sup>2</sup> )	1.0 {10}			
Seal material	Seal material	Mark	Working temperature range	Remarks
Working temperature range	Nitrile rubber	NBR (SG)	-20°C~+80°C	Standard material

### Max. Tightening Torque

N·m {kgf·cm}

Model	22PF • 25PF • 33PF	22PFB • 33PFB	22SF • 33SF	22SM	33SM
Torque	12 {122}	12 {122}	12 {122}	9 {92}	11 {112}

### Flow Direction

Fluid must run from socket to plug.



### Interchangeability

To prevent accidental interconnection, no Cuplas for oxygen (1/4" and 5/16") can be connected with those for fuel gas Cuplas (5/16" and 3/8"). However, oxygen plugs and sockets are interchangeable and fuel gas plugs and sockets are interchangeable.

\*Also Mini Cupla models for oxygen are interchangeable with Mini Cupla Super models for oxygen, while fuel gas models are interchangeable.

### Min. Cross-Sectional Area

(mm<sup>2</sup>)

Model	22SP • 25SP	33SP • 35SP
Min. cross-sectional area	20	44

### Suitability for Vacuum

Not suitable for vacuum application in either connected or disconnected condition.

### Pressure - Flow Characteristics

[Test conditions] • Fluid : Air • Temperature : Room temperature

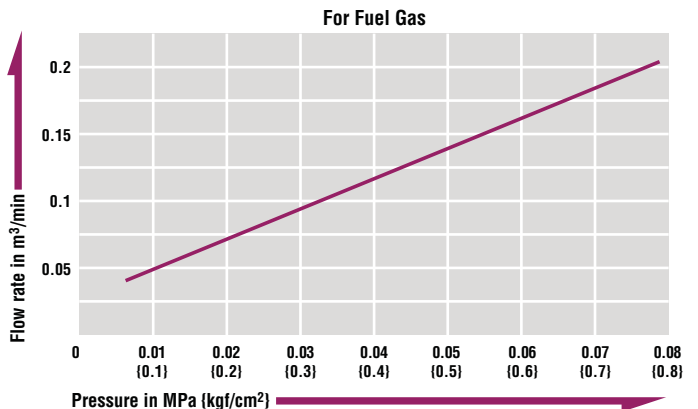
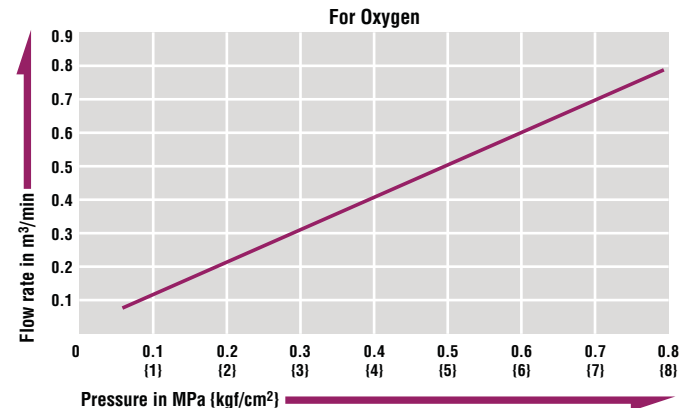

**Plug PH type (Hose barb)**

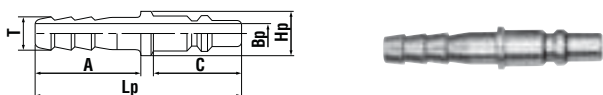

Usage	Model	Application (Hose)	Mass (g)	Dimensions (mm)					
				Lp	C	A	øHp	øT	øBp
For Oxygen	22PH	1/4"	16	55	23.5	28	11	7.8	5
	25PH	5/16"	19					9	
For Fuel Gas	33PH	3/8"	22	57	25.5	28	14	10.5	7.5
	35PH	5/16"	20					9	

**Socket SH type (Hose barb)**

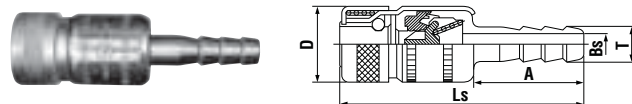

Usage	Model	Application (Hose)	Mass (g)	Dimensions (mm)				
				Ls	øD	A	øT	øBs
For Oxygen	22SH	1/4"	52	(64)	19.8	29	7.8	5
	25SH	5/16"	55				9	
For Fuel Gas	33SH	3/8"	69	(65)	22.6	29	10.5	7.5
	35SH	5/16"	67				9	

**Plug PF type (Female thread for torch connection)**

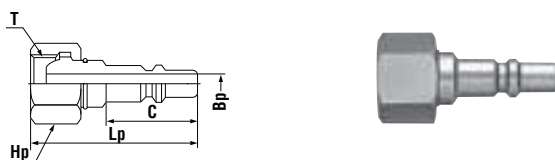

Usage	Model	Application	Mass (g)	Dimensions (mm)				
				Lp	C	Hp(WAF)	T	øBp
For Oxygen	22PF	For oxygen torch side	31	(43)	23.5	Hex.19	M16x1.5	5
	25PF		26	(43.5)		Hex.17	W12.5-20	
For Fuel Gas	33PF	For fuel gas torch side	36	(44.5)	25.5	Hex.19	M16x1.5 left-hand thread	7.5

**Socket SF type (Female thread for cylinder connection)**

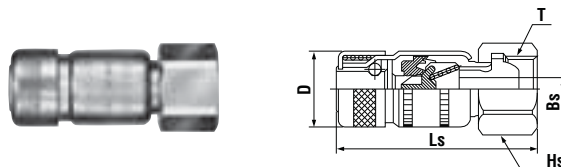

Usage	Model	Application	Mass (g)	Dimensions (mm)				
				Ls	øD	T	øBs	Hs(WAF)
For Oxygen	22SF	For oxygen gauge side	80	(52)	19.8	M16x1.5	5	Hex.19
For Fuel Gas	33SF	For fuel gas gauge side	96	(54)	22.6	M16x1.5 left-hand thread	5	Hex.19

**Plug PHB type (Hose barb with backflow stop valve)**

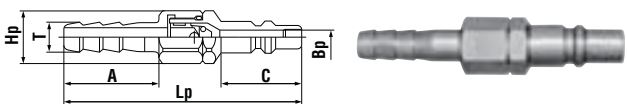

Usage	Model	Application (Hose)	Mass (g)	Dimensions (mm)					
				Lp	C	A	øHp	øT	øBp
For Oxygen	22PHB	1/4"	31	(69.6)	23.5	28	15.5	7.8	4.5
	25PHB	5/16"	34					9	
For Fuel Gas	33PHB	3/8"	41	(70.6)	25.5	28	15.5	10.5	4.5
	35PHB	5/16"	39					9	

**Socket SM type (Male thread)**

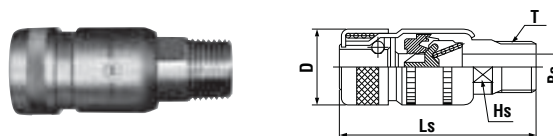

Usage	Model	Application	Mass (g)	Dimensions (mm)				
				Ls	øD	Hs(WAF)	T	øBs
For Oxygen	22SM	Rc 1/4	51	(52)	19.8	12	R 1/4	7.5
For Fuel Gas	33SM	Rc 3/8	77	(55)	22.6	14	R 3/8	10

**Plug PFB type (Female thread with backflow stop valve for torch connection)**

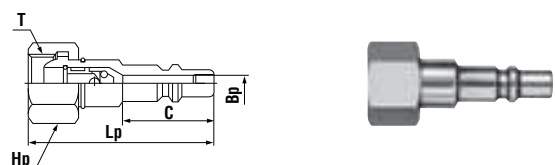

Usage	Model	Application	Mass (g)	Dimensions (mm)				
				Lp	C	Hp(WAF)	T	øBp
For Oxygen	22PFB	For oxygen torch side	36	(48.5)	23.5	Hex.19	M16x1.5	4.5
For Fuel Gas	33PFB	For fuel gas torch side	41	(49)	25.5	Hex.19	M16x1.5 left-hand thread	4.5

**Plug PMT type (Male thread)**

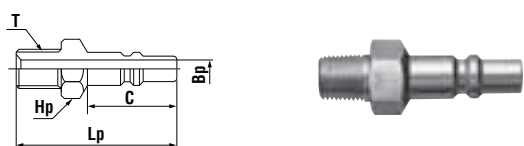

Usage	Model	Application	Mass (g)	Dimensions (mm)				
				Lp	C	Hp(WAF)	T	øBp
For Oxygen	21PMT	Rc 1/8	22	43.5	24	Hex.14	R 1/8	5
	22PMT	Rc 1/4	27	45	24	Hex.14	R 1/4	5

**Socket Line Cupla Mini LM-32 (For three port branch piping)**

Mass : 4,300g

• Dust caps come with this product as the standard accessory.

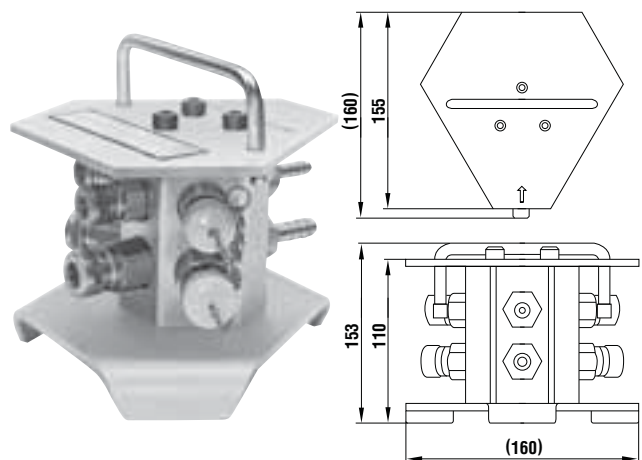

Line Cupla Mini contains:			
	For Oxygen	For Fuel Gas	Qty
Supply port	1/4"	3/8"	Each 1pc.
Gas outlets	22SM	33SM	Each 3pc.
Accessories (Plug with backflow stop valve)	22PHB	33PHB	Each 3pc.

For Low Pressure

# Mini Cupla Super

Heavy-duty push-to-connect type for oxyacetylene piping

<b>Working pressure</b>	<b>Valve structure</b>	<b>Applicable fluids</b>
0.7 MPa (7 kgf/cm <sup>2</sup> )	One-way shut-off	Oxygen, Fuel Gas

## Exclusively for welding and cutting equipment.

- From cylinders to torches, all piping connections associated with welding and cutting equipment are push-to-connect operations.
- Chrome-plated body for better corrosion resistance.
- Heat-treated plugs for better durability.
- Oxygen and fuel gas Cuplas have different configuration sizes with sleeves in different appearances, chrome plating for oxygen and copper plating for fuel gas, to prevent accidental interconnection.
- Smaller diameter design enables wider range of applications.
- Various types of end configurations have been standardized to comply with a wide range of welding and cutting equipment applications. Sockets themselves or plugs themselves are interchangeable with Mini Cupla's counterparts.

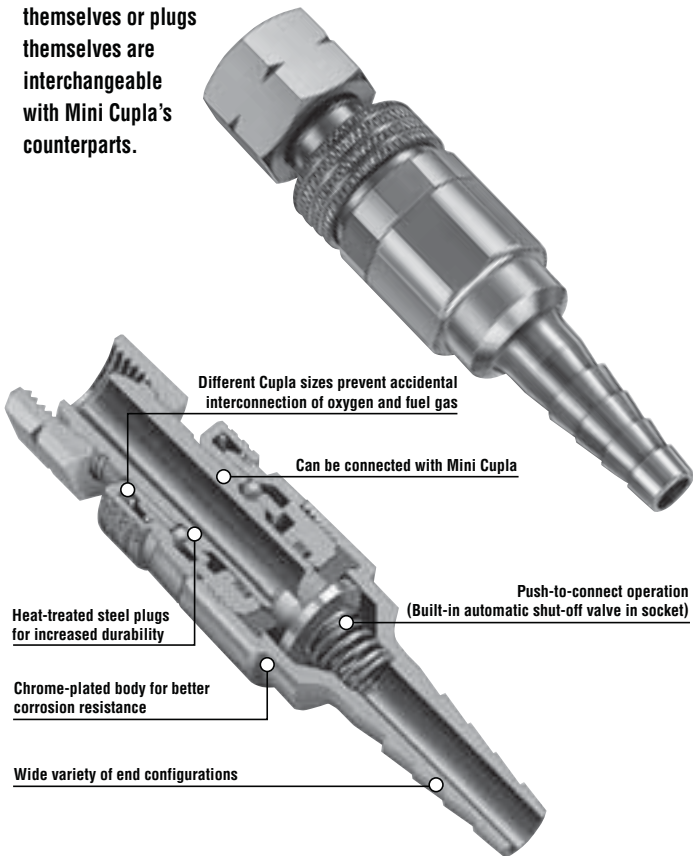

### Structure and Principle of Backflow Prevention

#### Plug with backflow stop valve

Plugs with backflow stop valve in Mini Cupla Super are designed exclusively for gas welding/cutting to prevent occurrence of gas mixing. Possible backflow of gas during operation can be stopped by cutting the back flow into the cylinder or line. Such valve is adopted in both fuel gas and oxygen plug.

Cross-section sketch showing the structure

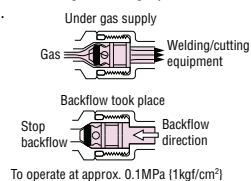
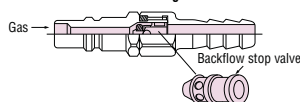

### Specifications

Body material	Socket : Brass (Chrome-plated) Plug : Steel (Chrome-plated)			
Size	1/4" • 5/16" • 3/8"			
Working pressure MPa (kgf/cm <sup>2</sup> )	0.7 (7)			
Pressure resistance MPa (kgf/cm <sup>2</sup> )	1.0 (10)			
Seal material	Seal material	Mark	Working temperature range	Remarks
Working temperature range	Nitrile rubber	NBR (SG)	-20°C~+80°C	Standard material

### Max. Tightening Torque

N·m (kgf·cm)

Model	S22PF • S22SF • S33PF • S33SF	S22SM	S33SM
Torque	12 (122)	9 (92)	11 (112)

### Flow Direction

Fluid must run from socket to plug.



### Interchangeability

To prevent accidental interconnection, no Cuplas for oxygen (1/4" and 5/16") can be connected with those for fuel gas Cuplas (5/16" and 3/8"). However, oxygen plugs and sockets are interchangeable and fuel gas plugs and sockets are interchangeable.

\*Also Mini Cupla Super models for oxygen are interchangeable with Mini Cupla models for oxygen, while fuel gas models are interchangeable.

### Min. Cross-Sectional Area

(mm<sup>2</sup>)

Model	S22SP	S33SP
Min. cross-sectional area	16	28

### Suitability for Vacuum

Not suitable for vacuum application in either connected or disconnected condition.

### Pressure - Flow Characteristics

[Test conditions] • Fluid : Air • Temperature : Room temperature

#### For Oxygen

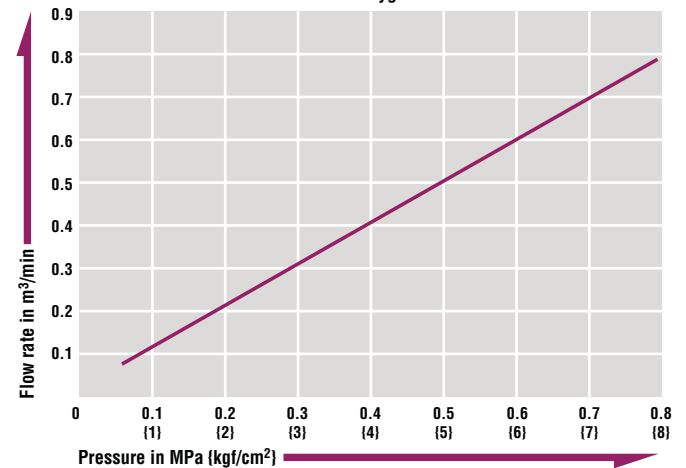

#### For Fuel Gas

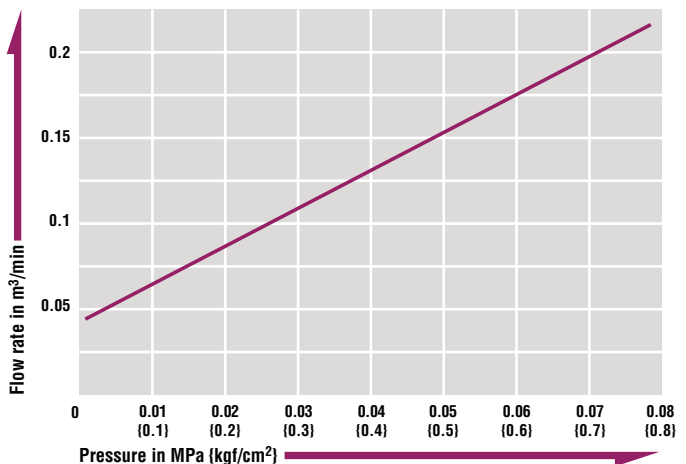

Models and Dimensions

**Plug PH type (Hose barb)**

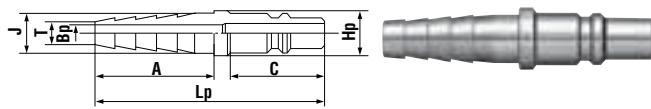

Usage	Model	Application (Hose)	Mass (g)	Dimensions (mm)						
				Lp	C	A	øHp	øT	øJ	øBp
For Oxygen	S22PH	1/4" • 5/16"	17	58	23.5	30	11	6.7	9.5	4.5
For Fuel Gas	S33PH	5/16" • 3/8"	22	59.5	25.5	30	14	7.5	11	6
For Fuel Gas	S32PH *1	1/4" • 5/16"	20	59.5	25.5	30	14	6.2	9	4.5

**Plug PH type (Hose barb for smaller diameter hose)**

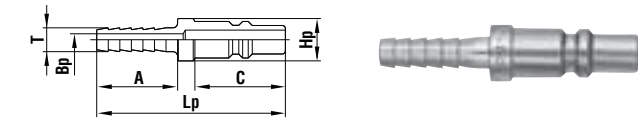

Usage	Model	Application (Hose)	Mass (g)	Dimensions (mm)					
				Lp	C	A	øHp	øBp	øT
For Oxygen	S225PH	5mm ID	12	49	23.5	21	11	3.1	6.2
For Fuel Gas	S335PH	5mm ID	15	50.5	25.5	21	14	3.1	6.2

**Plug PF type (Female thread for torch connection)**

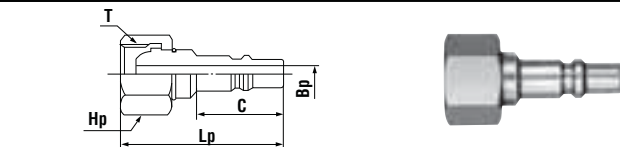

Usage	Model	Application	Mass (g)	Dimensions (mm)				
				Lp	C	Hp(WAF)	T	øBp
For Oxygen	S22PF	For oxygen torch side	35	(43)	23.5	Hex.19	M16x1.5	5
For Fuel Gas	S33PF	For fuel gas torch side	32	(44.5)	25.5	Hex.19	M16x1.5 left-hand thread	7.5

**Plug PFB type (Female thread with backflow stop valve for torch connection)**

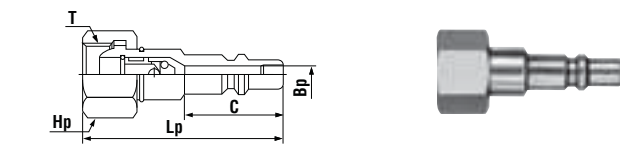

Usage	Model	Application	Mass (g)	Dimensions (mm)				
				Lp	C	Hp(WAF)	øT	øBp
For Oxygen	S23PFB-2 *1	For oxygen torch side	48	(51)	23.5	Hex.21	BS 3/8	4.5
For Fuel Gas	S33PFB-2 *1	For fuel gas torch side	52	(51)	25.5	Hex.21	BS 3/8 left-hand thread	4.5

**Plug PN type (Nut type for small diameter hose)**

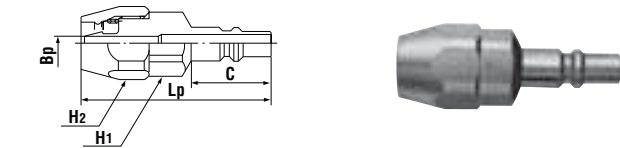

Usage	Model	Application (Hose)	Mass (g)	Dimensions (mm)				
				Lp	C	H1(WAF)	H2(WAF)	øBp
For Oxygen	S22PN	5mm ID *2	54	(53.5)	23.5	Hex.17	Hex.19	4.5
For Fuel Gas	S33PN	5mm ID *2	57	(54.5)	25.5	Hex.17	Hex.19	4.5

Application Example

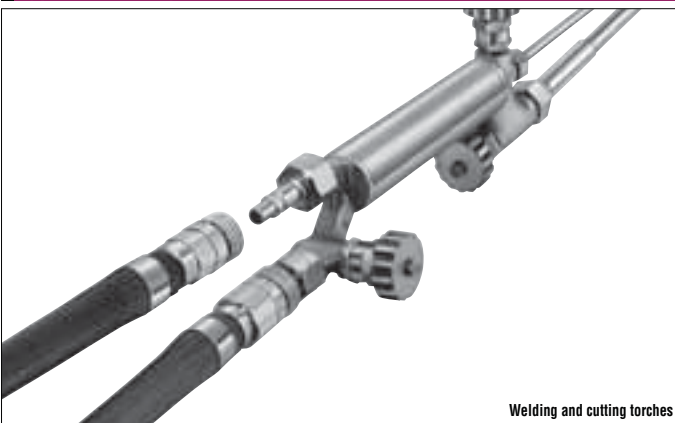

Welding and cutting torches

**Socket SH type (Hose barb)**

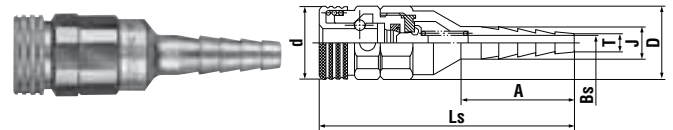

Usage	Model	Application (Hose)	Mass (g)	Dimensions (mm)						
				Ls	ød	øD	A	øT	øJ	øBs
For Oxygen	S22SH	1/4" • 5/16"	50	(64.5)	19.5	20	30	6.7	9.5	4.5
For Fuel Gas	S33SH	5/16" • 3/8"	73	(68)	22	22	30	7.5	11	6
For Fuel Gas	S32SH *1	1/4" • 5/16"	74	(72.5)	22	22	30	6.2	9	4.5

**Socket SH type (Hose barb for smaller diameter hose)**

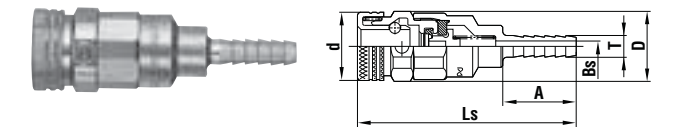

Usage	Model	Application (Hose)	Mass (g)	Dimensions (mm)					
				Ls	ød	øD	A	øBs	øT
For Oxygen	S225SH	5mm ID	54	(62.5)	19.5	20	21	3.1	6.2
For Fuel Gas	S335SH	5mm ID	65	(63)	22	22	21	3.1	6.2

**Socket SF type (Female thread for cylinder connection)**

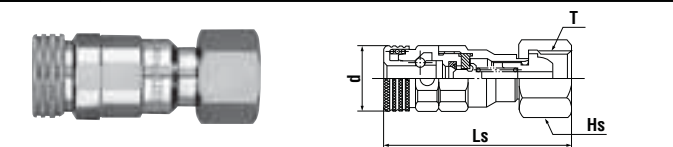

Usage	Model	Application	Mass (g)	Dimensions (mm)			
				Ls	øD	T	Hs(WAF)
For Oxygen	S22SF	For oxygen gauge side	74	(52.5)	19.5	M16x1.5	Hex.19
For Fuel Gas	S33SF	For fuel gas gauge side	97	(57.5)	22	M16x1.5 left-hand thread	Hex.19
For Oxygen	S23SF-BS *1	For oxygen gauge side	82	(55.5)	19.5	BS 3/8	Hex.21
For Fuel Gas	S33SF-BS *1	For fuel gas gauge side	88	(59)	22	BS 3/8 left-hand thread	Hex.21

**Socket SM type (Male thread)**

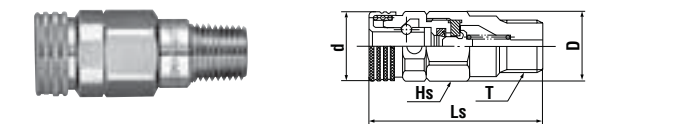

Usage	Model	Application (Hose)	Mass (g)	Dimensions (mm)				
				Ls	ød	øD	Hs(WAF)	T
For Oxygen	S22SM	Rc 1/4	58	(48.5)	19.5	20	Hex.18	R 1/4
For Fuel Gas	S33SM	Rc 3/8	85	(52)	22	23	Hex.21	R 3/8

**Socket SN type (Nut type for small diameter hose)**

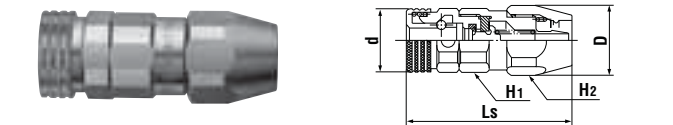

Usage	Model	Application (Hose)	Mass (g)	Dimensions (mm)				
				Ls	ød	øD	H1(WAF)	H2(WAF)
For Oxygen	S22SN	5mm ID *2	74	(52)	19.5	20.5	Hex.18	Hex.19
For Fuel Gas	S33SN	5mm ID *2	91	(57)	22	20.5	Hex.21	Hex.19

\*1 : Made-to-order item.

\*2 : Available hose sizes are ø5mm x ø11.2mm, ø5mm x ø11.5mm and ø5mm x ø11.8mm.

Select the combination in accordance with your own application.

Male thread	For regulator	For extension hose	For torch
Suggested combination SM x PH	Suggested combination SF x PH	Suggested combination SH x PH	Suggested combination SH x PF