



For Low Pressure (Air)

Line Cupla

200T Type, 200L Type, 200S Type

Simple design air line coupling on manifold

Working pressure  1.5 MPa (15 kgf/cm ²)	Valve structure  One-way shut-off	Applicable fluid  Air
--	--	--

Enables several air lines to be taken simultaneously from one supply line!

- Just push in the plug to socket for simple and secure connection!
- Multiple outlets are available from single air supply source.
- Choose from the 2-outlet type (Model 200T), the 5-outlet straight type (Model 200L) and the 5-outlet star type (Model 200S) to suit your application.

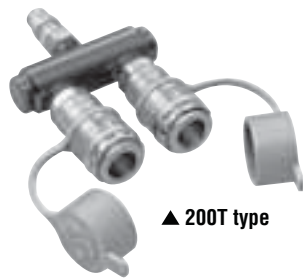

▲ 200T type

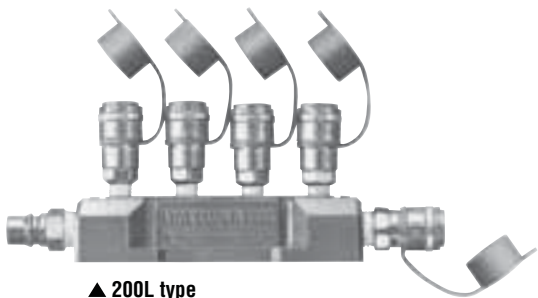

▲ 200L type
(comes with extra 400SH)

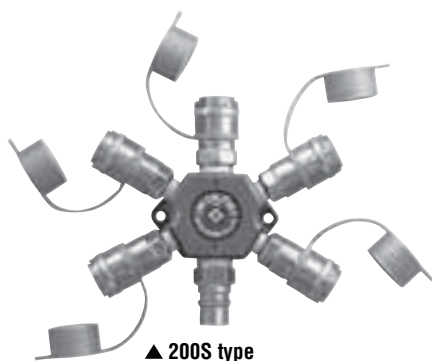

▲ 200S type
(comes with extra 400SH)

Specifications				
Body material	Body : Aluminum, Cupla : Steel (Chrome-plated)			
Size	Inlet	200T Type : 20PM	200L Type / 200S Type : 400PM	
	Outlet	200T Type : 200-20SM	200L Type / 200S Type : 200-20SM • 40SM	
Working pressure MPa (kgf/cm ²)	1.5 (15)			
Pressure resistance MPa (kgf/cm ²)	2.0 (20)			
Seal material	Seal material	Mark	Working temperature range	Remarks
Working temperature range	Nitrile rubber	NBR (SG)	-20°C~+60°C	Standard material

Flow Direction

Fluid must run from the inlet port to the outlet ports.

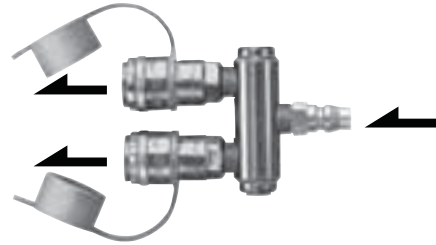

Interchangeability

Can be connected with plugs for Hi Cupla Models 20, 30 and 40. Interchangeable with each corresponding Hi Cupla Series models.

Min. Cross-Sectional Area (mm²)

Model	200T type, 200L type, 200S type
Min. cross-sectional area	19

Suitability for Vacuum

Not suitable for vacuum application in either connected or disconnected condition.

Pressure - Flow Characteristics

[Test conditions] • Fluid : Air • Temperature : Room temperature

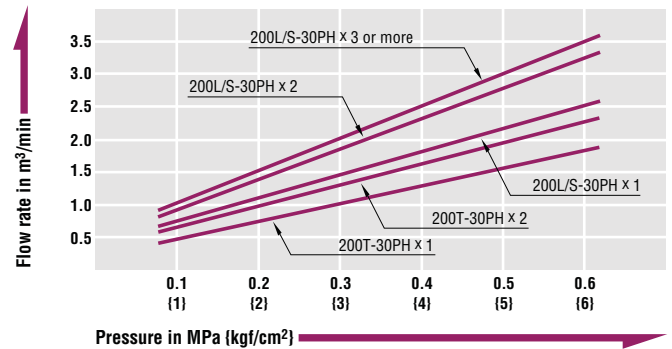

Number of Outlets in Use – Power Output (HP) Diagram (200L/200S types)

[Test conditions] • Fluid : Air • Temperature : Room temperature

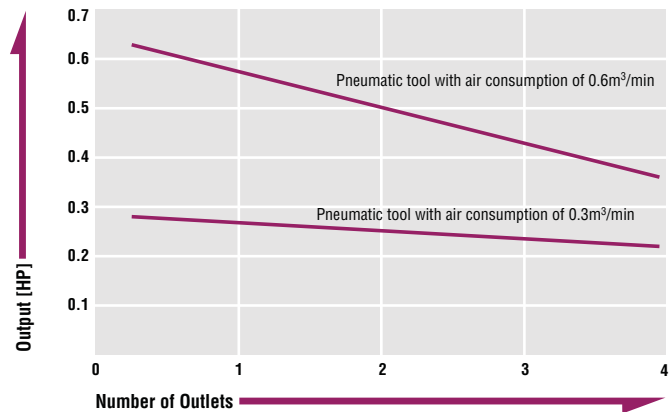

Socket 200T type (For two outlets)

Mass : 272g

- Fluid must run in the direction of the arrow.
- The product comes with dust caps.

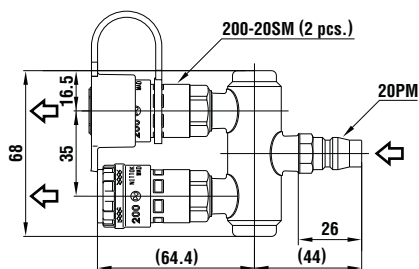

Dimensions (mm)

Socket 200L type (For five outlets, in line type)

Mass : 890g

- Fluid must run in the direction of the arrow.
- The product comes with dust caps.
- Accessory : 400SH

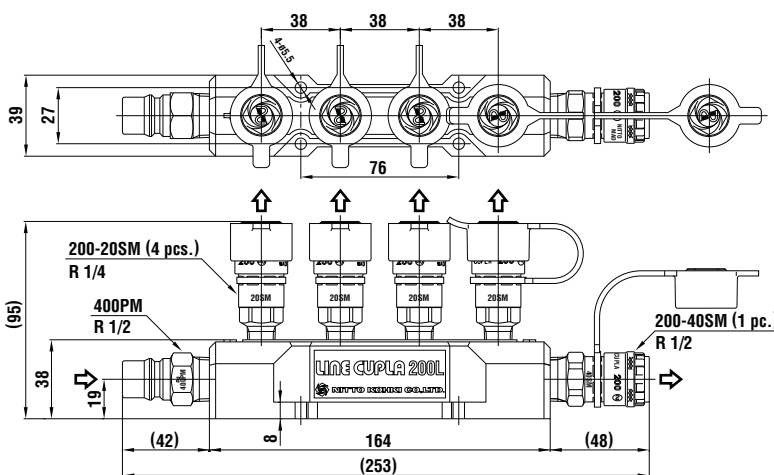

Dimensions (mm)

Socket 200S type (For five outlets, star type)

Mass : 769g

- Fluid must run in the direction of the arrow.
- The product comes with dust caps.
- Accessory : 400SH

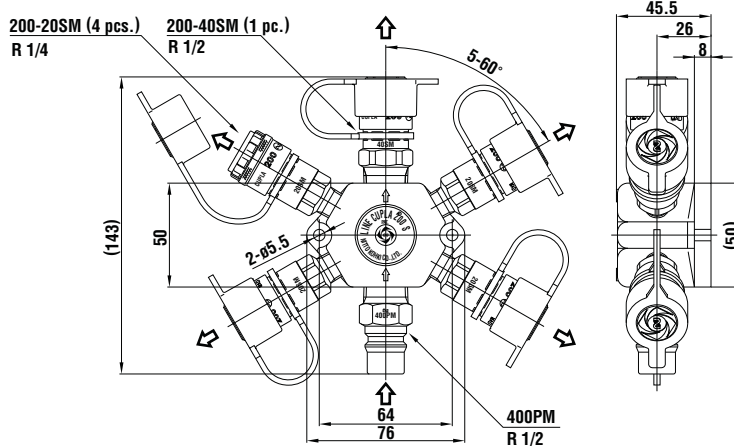

Dimensions (mm)

Application Example



Optional Items : Pressure Gauge and Drain Valve

"Pressure Gauge" and "Drain Cock" are available as optional items to be mounted on Line Cupla 200.

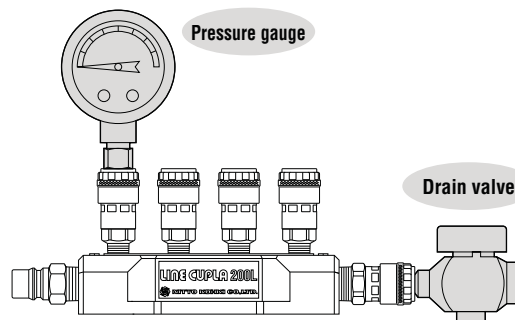

Actual appearance may differ due to incessant product improvements.